



BB12

w/6-5/8" API Reg Pin

Wt. 1,225 lbs.

EBB12-STD-Hammer

TAKES QL120 SHANKS

**SPECIAL BACKHEAD FEATURES – CALL OFFICE

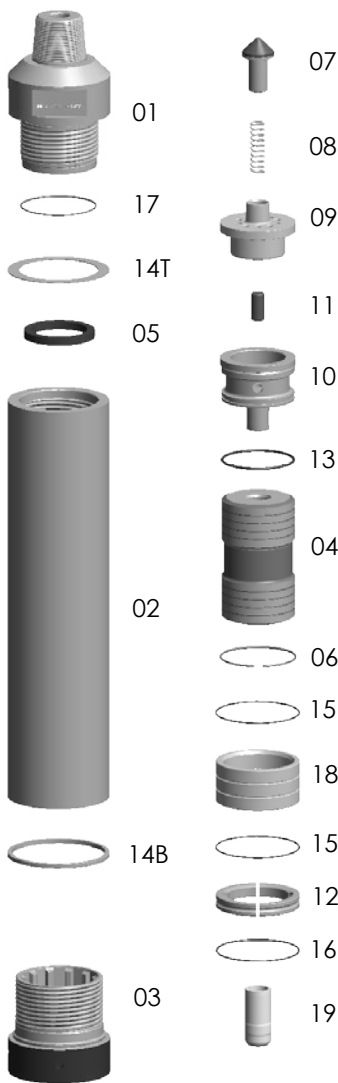

Replacement Parts

Hmr Part #	Description	Order #	Weight (lbs.)
BB12-01	Top Sub 6-5/8" API REG PIN w/O-Ring	EBB12-01	228.0
BB12-17	**Replacement O-Ring for Top Sub**	E12-17	0.1
BB12-02	Piston Case w/Retainer Ring	EBB12-02	509.0
BB12-06	**Replacement Retainer Ring for Piston Case**	E12-06	0.4
BB12-03	Chuck	EBB12-03	100.0
BB12-04	Piston	EBB12-04	170.0
BB12-05	Make Up Ring	E12-05	0.8
BB12-07	Check Valve Dart	E12-07	3.0
BB12-08	Check Valve Dart Spring	E12-08	0.3
BB12-09	Check Valve Guide	E12-09	30.0
BB12-10	Rigid Valve w/O-Ring	E12-10	32.0
BB12-13	**Replacement O-Ring for Rigid Valve**	E12-13	0.1
BB12-11	Choke Set (4)	E12-11	1.6
BB12-11A	Blank Choke	E12-11A	0.4
BB12-11B	1/8" Choke	E12-11B	0.4
BB12-11C	1/4" Choke	E12-11C	0.4
BB12-11D	3/8" Choke	E12-11D	0.4
BB12-12	Bit Retainer Ring w/O-Ring	EBB12-12	12.0
BB12-16	**Replacement O-Ring for Bit Retainer Ring**	E12-16	0.1
BB12-14T	Breakout Ring	EBB12-14T	2.0
BB12-14B	Breakout Ring	EBB12-14B	3.0
BB12-18	Bearing w/ (2) O-Rings	EBB12-18	0.1
BB12-15	**Replacement O-Ring for Bearing (uses 2)**	EBB12-15	0.1/ea.
BB12-19	Foot Valve	EQL120-24	1.0

Price is subject to change without notice.

	Outside Diameter		Hammer Length Shoulder To Shoulder				Bit Size Range		
	IN.	MM.	IN.	MM.	IN.	MM.			
BB12	11.2	285	55	1397	11 7/8 – 17 1/2	302 – 445			
Choke Size	100	6.9	150	10.3	200	250	17.2		
IN. MM.	PSI	BARS	PSI	BARS	PSI	BARS	PSI	BARS	
Blank	Blank	850	24.06	1200	33.98	1650	46.72	2000	56.63

The above air charts are based upon ideal conditions, your results may vary.