



T3.5

w/2-3/8"– API Reg Pin

Wt. 53 lbs.

T3-STD-Hammer

Thread Change/Pin
Box Thread

TAKES IR3.5 SHANKS

**SPECIAL BACKHEAD FEATURES—CALL OFFICE

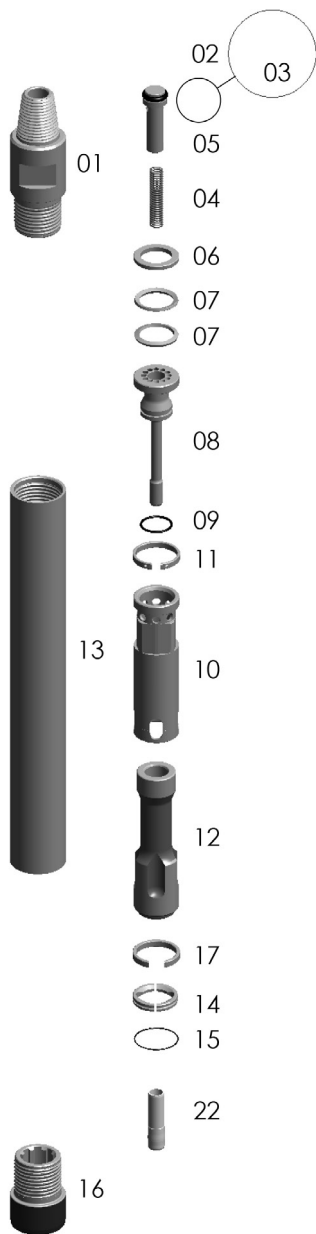

Replacement Parts

Hmr Part #	Description	Order #	Weight (lbs.)
T3-01	Backhead 2-3/8" API REG PIN	ET3-01	13.0
T3-03S	Choke Set	ET3-03S	0.3
T3-03	Blank Choke	ET3-03	0.1
T3-03A	1/8" Choke	ET3-03A	0.1
T3-03B	3/16" Choke	ET3-03B	0.1
T3-04	Check Valve Dart Spring	ET3-04	0.1
T3-05	Check Valve Dart w/O-Ring	ET3-05	0.6
T3-02	**Replacement O-Ring for Check Valve Dart**	ET3-02	0.1
T3-06	Spacer	ET3-06	0.2
T3-07	Disc Spring (requires 2)	ET3-07	0.1
T3-08	Air Distributor w/O-Ring	ET3-08	21.0
T3-09	**Replacement O-Ring for Air Distributor**	ET3-09	0.0
T3-10	Cylinder w/Retainer Ring	ET3-10	3.0
T3-11	**Replacement Cylinder Retainer Ring 2-holes**	ET3-11	0.2
T3-12	Piston	ET3-12	9.0
T3-13	Wear Sleeve w/Retainer Ring	ET3-13	20.0
T3-17	**Replacement Retainer Ring for Wear Sleeve**	ET3-17	0.2
T3-14	Bit Retainer Ring w/O-Ring	ET3-14	0.3
T3-15	**Replacement O-Ring for Bit Retainer Ring**	ET3-15	0.1
T3-16	Chuck	ET3-16	5.0
T3-22	Foot Valve	EIR3.5-22	0.5

	Outside Diameter		Hammer Length Pin				Bit Size Range				
	IN.	MM.	IN.	MM.	IN.	MM.					
T3.5	3.350	85.09	31.686	804.82	3-3/4–4-3/4	95.25–120.65					
Choke Size	175 PSI	12.07 BARS	200 PSI	13.8 BARS	250 PSI	17.2 BARS	300 PSI	20.7 BARS	350 PSI	24.1 BARS	
Blank	Blank	200	13.8	250	17.2	300	20.7	375	25.9	450	30.1
1/8	3.18										
3/16	4.76										

The above air charts are based upon ideal conditions, your results may vary.