



T8

w/4-1/2" API Reg Pin

Wt. 375 lbs.

T8-STD-Hammer

TAKES 380 SHANKS

Thread Change/Pin
Box Thread
Carbide Buttons
Special Flats
Side Carbide Buttons

**SPECIAL TOP SUB FEATURES—CALL OFFICE

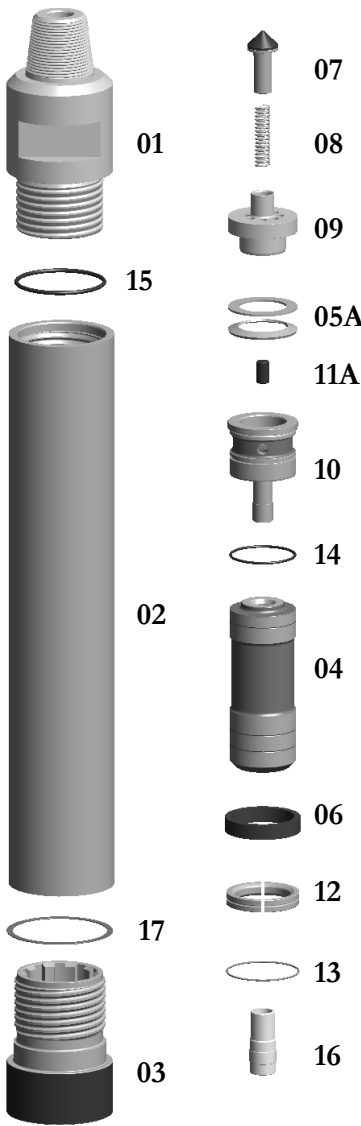

Replacement Parts

Hmr Part #	Description	Order #	Weight (lbs.)
T8-01	Top Sub w/4-1/2" API REG PIN w/O-Ring	EBB8-01	93.0
T8-15	**Replacement O-Ring for Top Sub**	E8-15	0.1
T8-02	Piston Case w/Retainer Ring	ET8-02	142.0
T8-06	**Replacement Retainer Ring for Piston Case**	ET8-06	0.3
T8-03	Chuck	E8-03	36.0
T8-04	Piston	ET8-04	70.0
T8-05A	Disc Spring / Spacer Ring Set	E8-05A	1.5
T8-07	Check Valve Dart	E8-07	1.5
T8-08	Check Valve Dart Spring	E8-08	0.3
T8-09	Check Valve Guide	E8-09	12.0
T8-10	Rigid Valve w/O-Ring	E8-10M	15.0
T8-14	**Replacement O-Ring for Rigid Valve**	E8-14	0.1
T8-11	Choke Set	E8-11(5)	1.5
T8-11A	Blank Choke	E8-11A	0.3
T8-11B	1/8" Choke	E8-11B	0.3
T8-11C	1/4" Choke	E8-11C	0.3
T8-11D	3/8" Choke	E8-11D	0.3
T8-11E	7/16" Choke	E8-11E	0.3
T8-12	Bit Retainer Ring w/O-Ring	ET8-12	3.0
T8-13	**Replacement O-Ring for Bit Retainer**	ET8-13	0.1
T8-16	Foot Valve	ET8-16	0.2
T8-17	Brass Break Out Ring (Optional) Top	E8-17	0.2
T8-17A	Brass Break Out Ring (Optional) Bottom	ET8-17	0.2

	Outside Diameter		Hammer Length Pin		Hammer Length Box		Bit Size Range	
	IN.	MM.	IN.	MM.	IN.	MM.	IN.	MM.
TH8	7-1/8	180.34	52-3/8	1330.5	52-7/8	1343	7-7/8-12	200-305