

EP5-Hammer-BK

TAKES QL5 SHANKS—NO FOOT VALVE

Thread Change/Pin
Box Thread
Carbide Buttons
Special Flats

**SPECIAL BACKHEAD FEATURES—CALL OFFICE

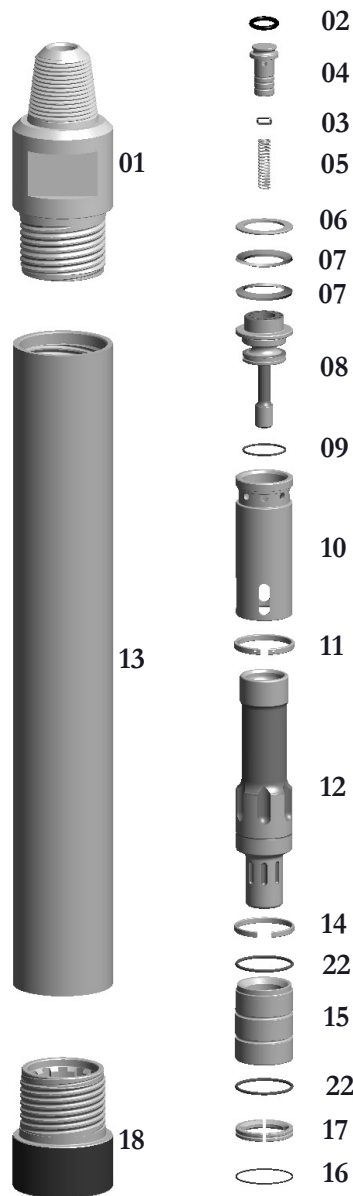

Replacement Parts

Hmr Part #	Description	Order #	Weight (lbs.)
P5.5-01	Backhead 3-1/2" API REG PIN	EBB5-01	42.0
P5.5-03(S)	Choke Set	EBB6-03S	0.3
P5.5-03	Choke - Blank	EBB6-03	0.1
P5.5-03A	1/8" Choke	EBB6-03A	0.1
P5.5-03B	3/16" Choke	EBB6-03B	0.1
P5.5-04	Check Valve Dart w/O-Ring	EBB6-04	1.1
P5.5-02	**Replacement O'Ring for Check Valve Dart**	EBB6-04A	0.1
P5.5-05	Check Valve Dart Spring	EP6-05	0.4
P5.5-06	Spacer	EBB5-06	0.2
P5.5-07	Disc Spring (Uses 2)	EBB5-07	0.3/ea
P5.5-08	Air Distributor w/O-Ring	EBB5-08	9.0
P5.5-09	**Replacement O-Ring for Air Distributor**	EBB5-09	0.1
P5.5-10	Cylinder w/Retainer Ring	EBB5-10	8.0
P5.5-11	**Replacement Retainer Ring for Cylinder**	EBB5-11	0.5
P5.5-12	Piston	EP5-12	36.0
P5.5-13	Wear Sleeve w/Retainer Ring	EP5-13	82.0
P5.5-14	**Replacement Retainer Ring for Wear Sleeve**	EBB5-14	0.2
P5.5-15	Bearing w/ O-Rings	EP5-15	7.0
P5.5-22	**Replacement O-Ring for Bearing (uses 2)**	E6-14	0.2/ea.
P5.5-17	Bit Retainer Ring w/O-Ring	EBB5-17	0.77
P5.5-16	**Replacement O-Ring for Bit Retainer**	EBB5-16	0.1
P5.5-18	Chuck	EBB5-18	12.0
P5.5-18-DM	Chuck - Ductile	EBB5-18-DM	12.0
P5.5-20	Wear Washer (If needed)	EBB5-20	0.1

	Outside Diameter		Hammer Length Pin		Hammer Length Box		Bit Size Range		
	IN.	MM.	IN.	MM.	IN.	MM.	IN.	MM.	
P5.5	4-7/8	123.95	41-7/16	1052	45-5/16	1145.6	5-1/4-6	139-149	
Choke Size	200 PSI	13.8 BARS	250 PSI	17.2 BARS	300 PSI	20.7 BARS	350 PSI	24.1 BARS	
Blank	Blank	500	14.16	560	15.86	765	21.66	900	25.48
1/8	3.18	520	14.72	598	16.93	813	23.02	950	26.90
3/16	4.76	550	15.57	640	18.12	872	24.69	1022	28.94

The above air charts are based upon ideal conditions, your results may vary.